

C858 McD

Electric Clamshell Grill

Features



One-touch menu selection automatically chooses the proper TIME, TEMPERATURE, and GAP settings.

True Parallel Auto Leveling

Automated procedure sets the lower plate parallel to the upper platen. Increases food quality through consistently accurate gap settings.

Programmable Controls

Automatically determines product placed on the grill and sets cook time and multi-gap parameters. Easier to operate and eliminates need to change product settings, which improves flexibility. Microprocessor controls are programmable for simplified crew operation. Also offers flexibility for future menu items and product specification changes at the restaurant level.

Upper Platens

Upper platen may be lowered manually for quick closing, or will close automatically to the preset gap setting with the touch of one button. Slim platen design makes cleaning easier. As a safety feature, platen will automatically open at loss of power, or if an obstruction is detected.

Precise Automatic Gapping

With the unique three-point reference system, the lower plate automatically achieves accurate and consistent gaps every time. Precise, repeatable gapping results in consistent, better quality finished product.

Cooking Zones

Three controlled cooking positions. Three independent heating elements in the lower cooking surface, and two in the upper platen, assures even temperatures and quick recovery. A larger cooking gap allows products up to 2 in. thick to be cooked in two-sided mode, enabling greater menu flexibility.

Independent Platen Cooking Zones

Separate lower cook zones allow the user to turn them off during the slow periods to save energy, and provide a flexible cleaning schedule by cleaning a zone at a time instead of the entire grill. Each zone allows you to cook different menu items at different temperatures all day. There is no flavor or food transfer from zone to zone due to separation of independent cook zones.

Wrap-Around Release Material

Simple-to-install upper platen release material protects the entire upper platen cooking surface and makes cleaning easy. Improved installation and removal keeps hands away from hot surfaces.



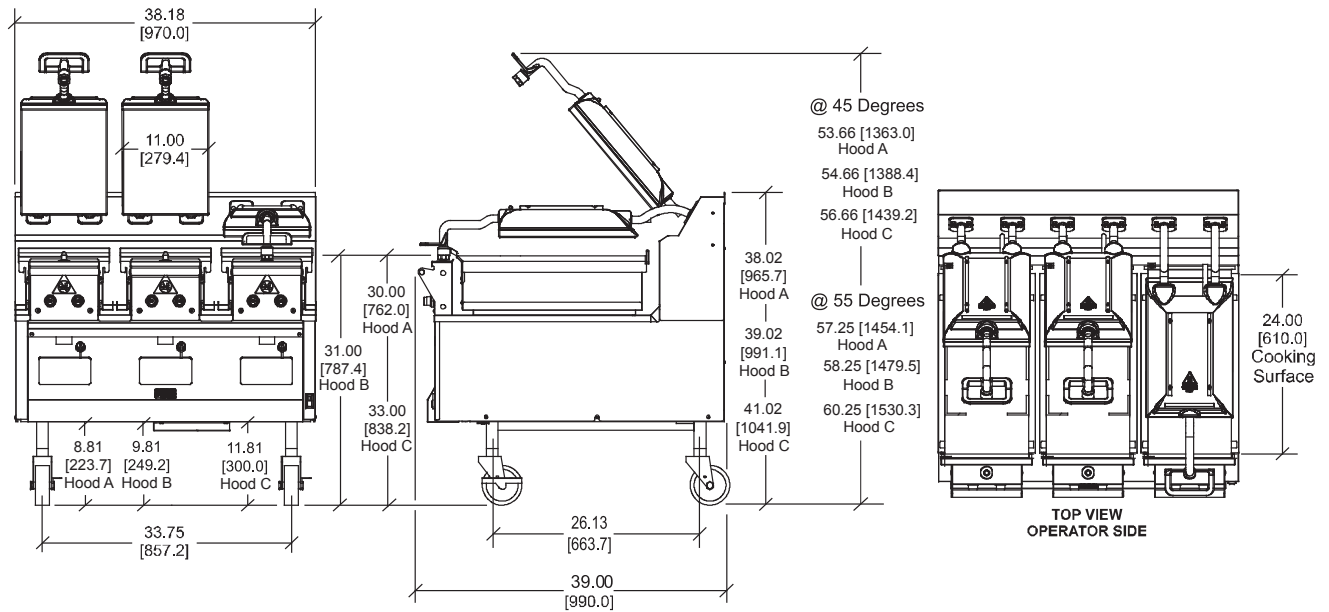

Figures in brackets indicate millimeters/decimals and fractional dimensions equal to (plus or minus 1/16 in. [1.5 mm]). Machine height can vary (plus or minus 2-1/2 in. [63.5 mm]) with caster height adjustment. Side grease cans not shown.

| Weights | lb. | kg |
|---------|-----|-----|
| Net | 890 | 404 |
| Crated | 940 | 426 |

*For reference only

| | cu. ft. | cu. m |
|------------------------|---------------------|--------------|
| Volume | 49.7 | 1.41 |
| Dimensions | in. | mm |
| Width | 38-3/16 | 970 |
| Depth | 39.0 | 990 |
| Height | 55-3/16 to 58-3/4 | 1401 to 1492 |
| Cooking Surface Height | 29 to 34 | 737 to 864 |
| Floor Clearance | 6-13/16 to 11-13/16 | 173 to 300 |

*Casters may be adjusted

| Electrical | Quantity of | Amps | Total KW | Control |
|-------------|-------------|------|----------|-------------|
| | 3-Phase | per | | Voltage |
| | Main Power | Cord | | Single |
| | Cords | Cord | | Phase Cord |
| 208/60/3 | 2 | 32 | 22 | 120/60/1 |
| 208/60/3 | 1 | 64 | 22 | — |
| 380/50/60/3 | 2 | 17 | 22 | 220/50/60/1 |
| 400/50/60/3 | 1 | 32 | 22 | — |

This unit may be manufactured with other electrical characteristics and may have additional regulatory agency approvals. Consult the local Taylor distributor for other electrical characteristics and agency approvals based on specific electrical and country requirements.

(For exact electrical information, approval marks, and refrigerant, always refer to the data label of the unit.)

Continuing research results in steady improvements. Therefore, these specifications are subject to change without notice.

Bidding Specs

Electrical: Volt _____ Hz _____ ph _____
 Neutral: Yes No **Cooling:** Air Water NA

Options: _____

Specifications

Electrical

Standard is 208/60/3 phase.

Three dedicated electrical connections are required; two three-phase and one interlock/control single-phase. See the electrical chart for the proper electrical requirements. Manufactured to be permanently connected. Consult your KES or local Taylor distributor for cord and receptacle specifications as local codes allow.

NOTE: Taylor Model C858 Clamshell Grills may be installed only in McDonalds Corporation Restaurants.

Authorized Taylor Distributor



750 N. Blackhawk Blvd.
 Rockton, Illinois 61072
www.taylor-company.com